



Figur **497**

Zwischenflanschanschluss
Durchgangsform

 **ABSPERRKLAPPE zBUT**



Gehäusewerkstoff	Nenndruck	Nennweite	max. Temperatur
B Sphäroguss	C 16 bar	DN 32-300	110°C
	B 10 bar	DN 350-600	

MERKMALE

- hoher Dichtheitsgrad
- Dichtung aus EPDM/NBR
- zentrisch gelagerte Klappenscheibe
- umweltfreundlich

ANWENDUNG

- Kalt- und Kühlwasseranlagen
- Heizungsanlagen
- Trink- und Nutzwasseranlagen
- Erdgasleitungen
- Kanalisation
- Schiffbau
- Energietechnik

Konstruktionsänderungen vorbehalten.

Ausgabe 06/2016



Figur **497**

Zwischenflansanschluss
Durchgangsform

WERKSTOFFE

Ausführung **497 DN32 - DN300**

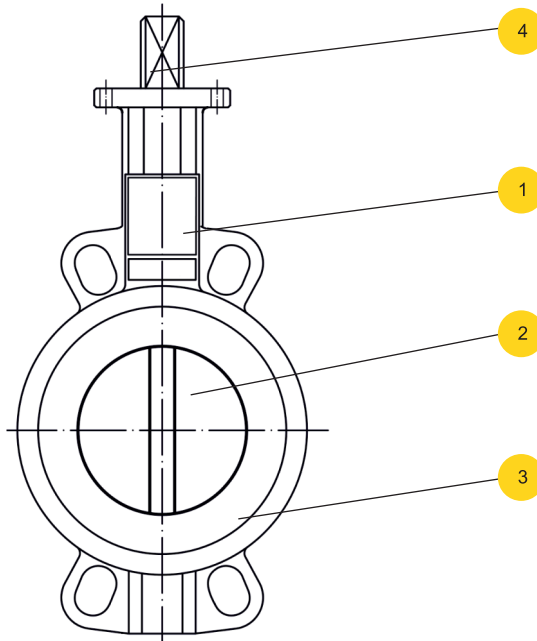

Ausführung **497 DN350 - DN600**

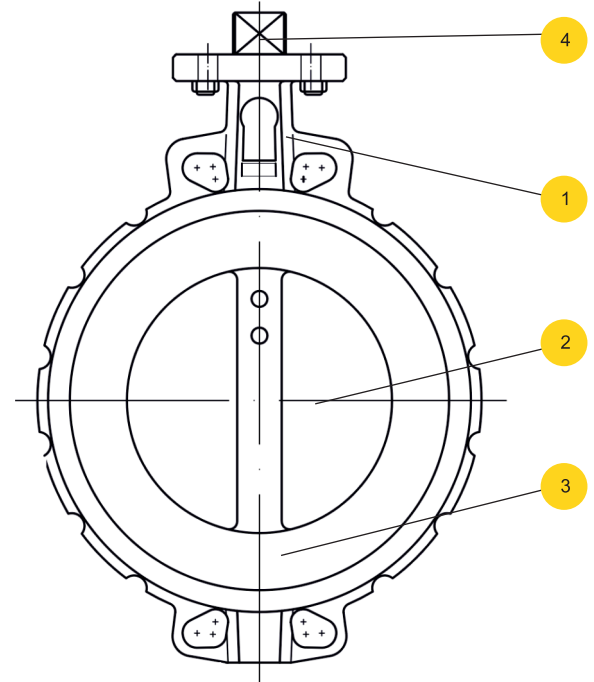

	Gehäusewerkstoff	B			
		Ausführung			
		67	D6	68	A6
1	Gehäuse	EN-GJS-400-15 5.3106 (ex.JS 1030) + EPOXY			
2	Scheibe	EN-GJS-400-15 5.3106 (ex.JS 1030) + EPOXY		1.4408	
3	Sitz	EPDM			
4	Schaft	AISI 416			
	max. Temperatur	110°C			



Figur **497**

Zwischenflansanschluss
Durchgangsform

ABMESSUNGEN

Type 497 DN32 - DN300

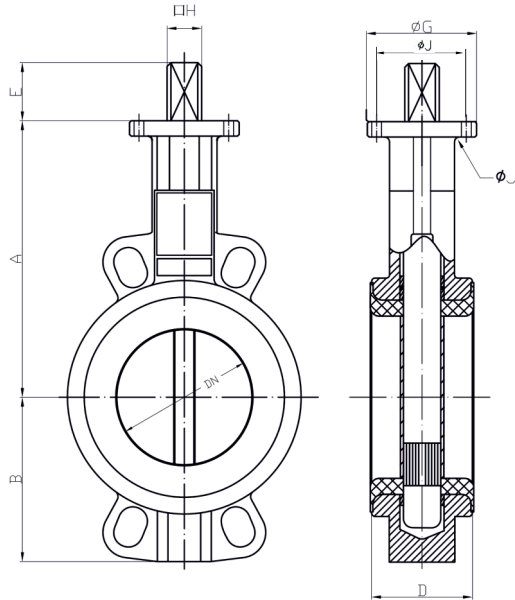

Type 497 DN350 - DN600

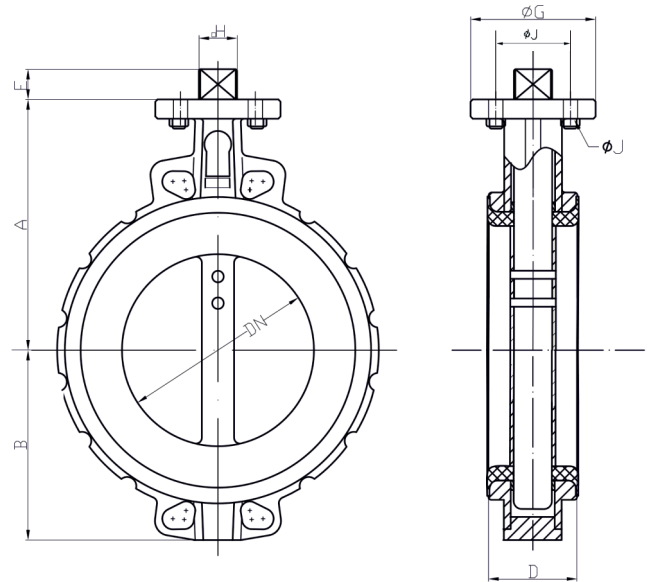

DN		A	B	D	øG	E	H	øJ	n x øM	ISO	torque*		
mm	inch	mm										Nm	kg
32	1 1/4"	116	60	33	65	32	7 x 7	50	4 x ø7	F-05	11	1,60	
40	1 1/2"	125	64	33	65	32	9 x 9	50	4 x ø7	F-05	11	1,70	
50	2"	132	75	43	65	32	9 x 9	50	4 x ø7	F-05	16	2,20	
65	2 1/2"	137	86	46	65	32	9 x 9	50	4 x ø7	F-05	26	2,70	
80	3"	153	93	46	65	32	9 x 9	50	4 x ø7	F-05	33	2,90	
100	4"	175	105	52	65	32	11 x 11	50	4 x ø7	F-05	53	4,40	
125	5"	187	120	56	90	42	14 x 14	70	4 x ø9	F-07	81	6,50	
150	6"	210	142	56	90	42	14 x 14	70	4 x ø9	F-07	119	7,60	
200	8"	237	169	60	125	36	17 x 17	102	4 x ø11	F-10	194	14,00	
250	10"	275	203	68	150	38	22 x 22	125	4 x ø13	F-12	308	21,20	
300	12"	305	233	78	150	38	27 x 27	125	4 x ø13	F-12	595	33,65	
350	14"	334	260	78	150	45	27 x 27	125	4 x ø14	F-12	969	54,50	
400	16"	361	307	102	150	50	27 x 27	125	4 x ø14	F-12	1307	89,85	
450	18"	401	339	114	210	50	30 x 30	165	4 x ø22	F-16	1787	107,40	
500	20"	480	368	127	210	65	36 x 36	165	4 x ø22	F-16	2288	155,75	
600	24"	565	459	154	300	70	46 x 46	165	4 x ø22	F-16	3711	231,10	

*for correct actuator selection it is recommended to add 30% of correction coefficient

Konstruktionsänderungen vorbehalten.

Ausgabe 06/2016



Figur **497**

Zwischenflanschanschluss
Durchgangsform

ABMESSUNGEN

Lock lever 497 DN32 - DN150

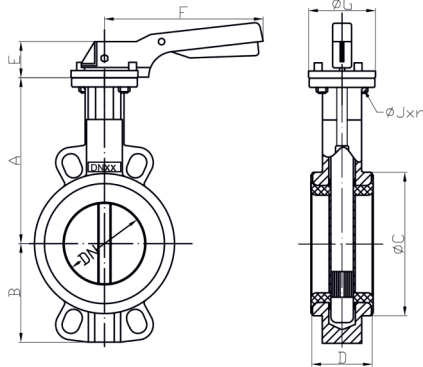

Lock lever 497 DN200 - DN300

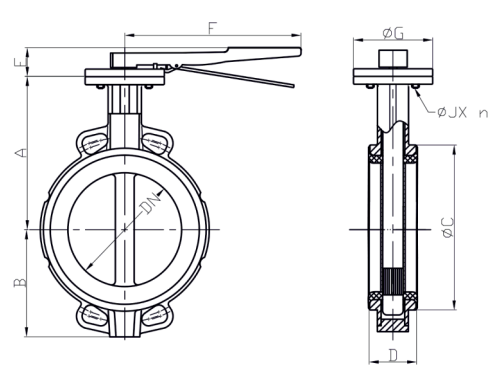

DN		A	B	D	ØC	E	F	ØG	ØJ
mm	inch	mm							
32	1 1/4"	116	55	33	73	70	195	65	50
40	1 1/2"	125	59	33	82	70	195	65	50
50	2"	132	75	43	90	70	195	65	50
65	2 1/2"	137	86	46	103	70	195	65	50
80	3"	153	93	46	120	70	195	65	50
100	4"	175	105	52	152	70	195	65	50
125	5"	187	120	56	180	71	278	90	70
150	6"	210	142	56	207	71	278	90	70
200	8"	237	169	60	260	44	355	125	102
250	10"	275	203	68	315	44	507	150	125
300	12"	305	233	78	370	44	507	150	125

Gearbox 497 DN100 - DN300

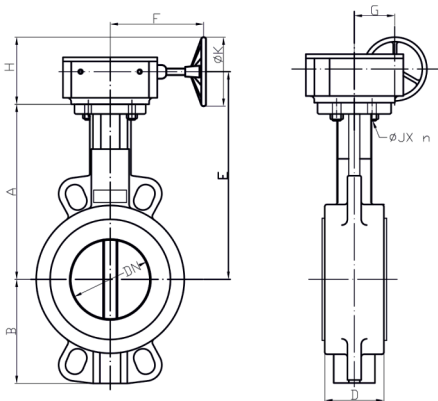

Gearbox 497 DN350 - DN600

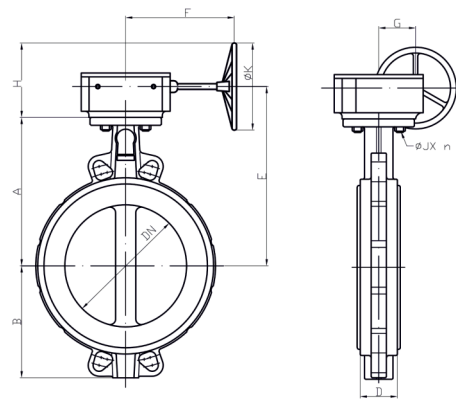

DN		A	B	D	E	F	G	G	ØK	ØJ
mm	inch	mm								
100	4"	175	105	52	221	156	45	116	150	50
125	5"	187	120	56	233	156	45	168	250	70
150	6"	210	142	56	256	156	45	168	250	70
200	8"	237	169	60	284	241	63	193	300	102
250	10"	275	203	68	320	223	78	190	300	125
300	12"	305	233	78	350	223	78	190	300	125
350	14"	334	260	78	379	223	78	190	300	125
400	16"	361	307	102	423	270	120	208	400	125
450	18"	401	339	114	463	270	120	258	400	165
500	20"	480	368	127	545	339	120	222	300	165
600	24"	565	459	154	630	339	120	222	300	165

Konstruktionsänderungen vorbehalten.

Ausgabe 06/2016



Figur **497**

Zwischenflanschanschluss
Durchgangsform

KV KOEFFIZIENT

DN	32/40	50	65	80	100	125	150	200	250	300	350	400	450	500	600	
Opening angle	10°	0,04	0,05	0,09	0,17	0,26	0,43	0,68	1,7	2,6	3,4	5,1	6,8	9,4	11,9	18,8
	20°	2	3	5	8	15	25	38	76	129	200	288	396	525	675	1042
	30°	5	6	10	15	31	52	81	160	273	422	610	839	1101	1428	2207
	40°	10	13	21	33	67	113	175	348	592	914	1321	1817	2407	3095	4781
	50°	18	23	38	60	119	202	312	620	1055	1630	2355	3239	4289	5515	8521
	60°	30	38	64	99	196	334	516	1025	1746	2697	3897	5359	7097	9125	14098
	70°	48	60	102	156	310	529	817	1623	2764	4269	6167	8481	11232	14442	22312
	80°	72	90	152	235	466	793	1226	2434	4145	6403	9250	12720	16848	21662	33468
	90°	78	98	167	258	512	872	1347	2675	4555	7037	10165	13799	18514	23805	36778

AUSFÜHRUNG





Figur **497**

Zwischenflansanschluss
Durchgangsform

BESTELLANGABEN

Das Produkt mit Indexangabe bestellen



BESTELLBEISPIEL

497 B 040 C 68-J

Absperrklappe, Zwischenflansanschluss, Durchgangsform

497

Sphäroguss EN-GJS-400-15

B

Nennweite DN40

040

Nenndruck PN16

C

Scheibe- Stahl rostfrei • Hebel • EPDM-Dichtung

68-J

**Figur 497**Zwischenflansanschluss
Durchgangsform **ABSPERRKLAPPE zBUT**

Gehäusewerkstoff	Nenndruck	Nennweite	max. Temperatur
A Grauguss	C 16 bar	DN 32-150	210°C*
	B 10 bar	DN 200-900	
	A 6 bar	DN 1000-1200	
B Sphäroguss	C 16 bar	DN 32-150	210°C*
	B 10 bar	DN 200-1200	

*Die maximale zulässige Temperatur hängt von dem verwendeten Materialien

MERKMALE

- hoher Dichtheitsgrad (Dichtheitsklasse: - A nach EN – 12266)
- Baulänge nach EN 558
- Flansche PN10/PN16 nach EN 1092
- Dichtung aus EPDM/NBR/FLUCAST/ SILICONE/ VITON/ HYPALON/EPICHLOROHYDRIN/ NEOPREN/ BUTYL
- Scheibe Sphäroguss, Edelstahl/Aluminium/Bronze/Alu-bronzeStahlguss/Duplex/Superduplex umweltfreundlich

ANWENDUNG

- Kalt- und Kühlwasseranlagen
- Heizungsanlagen
- Schiffbau
- Energietechnik
-
-
-

Konstruktionsänderungen vorbehalten.

Ausgabe 06/2016



Figur **497**

Zwischenflanschsanschluss
Durchgangsform

WERKSTOFFE

Ausführung 497 DN32

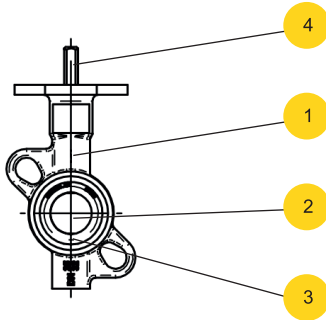

Ausführung 497 DN40 - D400

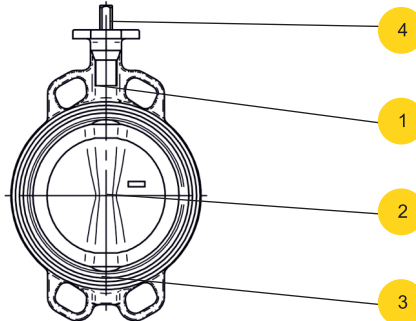

Ausführung 497 DN80

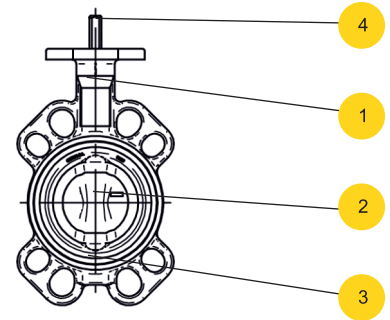

Ausführung 497 DN450

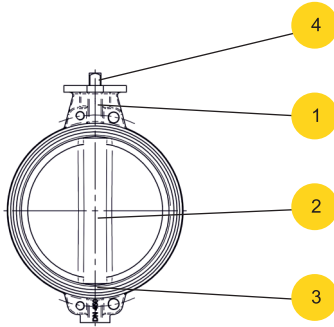

Ausführung 497 DN500 - DN700

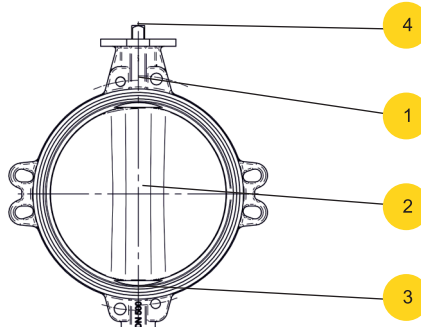

Ausführung 497 DN750 - DN1200

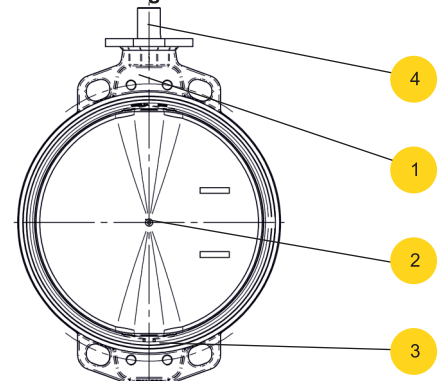

Gehäusewerkstoff		A		B	
Ausführung		26-I, 66-I, C6-I	06-I, 36-I, A6-I	26-I, 66-I, C6-I	06-I, 36-I, A6-I
1	Gehäuse	EN-GJL-250 5.1301 (ex.JL 1040) + EPOXY		EN-GJS-400-15 5.3106 (ex.JL 1030) + EPOXY	
2	Scheibe	EN-GJS-400-15 5.3106 (ex.JL 1030)	1.4408	EN-GJS-400-15 5.3106 (ex.JL 1030)	1.4408
3	Sitz	EPDM			
4	Schaft	AISI 416			
max. Temperatur		120°C			



Figur **497**

Zwischenflanschsanschluss
Durchgangsform

ABMESSUNGEN

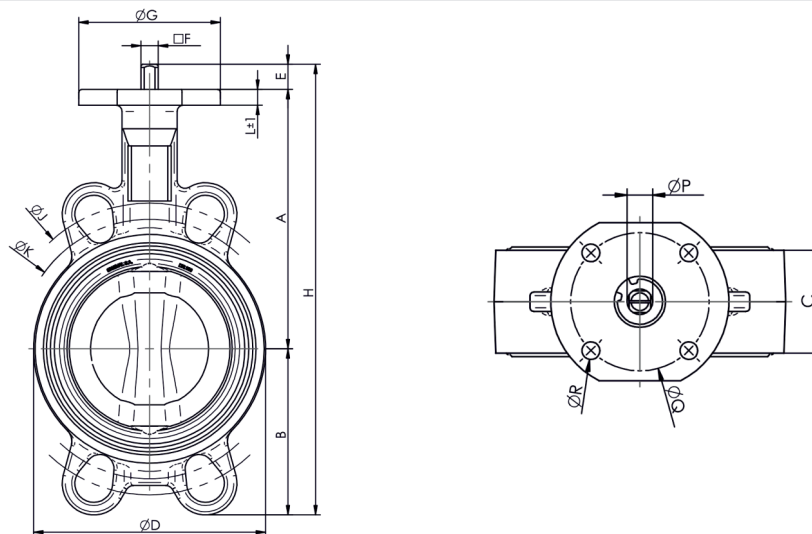

DN		A	B	C	D	E	F	G	H	J	K	Q	R x ØM	ISO	Torque		
mm	inch	mm														Nm	kg
32	1 1/4"	102,5	60,2	33	68	30	11	90	192,7	100	85	70	4 x Ø7	F-07	15	1,50	
40	1 1/2"	110	56	33	76	30	11	90	196	110	95	70	4 x Ø9	F-07	15	1,70	
50	2"	120	61,5	43	100	30	11	90	211,5	123	120,6	70	4 x Ø9	F-07	17	2,40	
65	2 1/2"	135	69	46	108	30	11	90	234	145	127	70	4 x Ø9	F-07	25	2,60	
80	3"	141	94	46	124	30	11	90	265	160	145	70	4 x Ø9	F-07	28	3,10	
100	4"	165	106	52	147	30	11	90	301	185,5	165	70	4 x Ø9	F-07	50	4,00	
125	5"	180	126,5	56	180	33	14	90	339,5	225	206	70	4 x Ø9	F-07	85	6,10	
150	6"	193	133	56	206	33	14	90	359	241,3	229	70	4 x Ø9	F-07	110	7,30	
200	8"	225	170	60	257	33	17	90	428	305	280	70	4 x Ø9	F-07	140	11,00	
250	10"	282,5	210	68	324	23	22	130	515,5	362	335	102	4 x Ø12	F-10	270	20,50	
300	12"	308	240	78	376	23	22	130	571	431,8	394	102	4 x Ø12	F-10	390	29,50	
350	14"	338,5	263	78	430	31	22	160	632,5	476,3	445	102	4 x Ø12	F-10	500	35,40	
400	16"	380	308	102	485	31	27	160	719	540	510	125	4 x Ø12	F-12	897	55,70	
450	18"	380,5	340	114	536	38	36	190	758,5	-	-	140	4 x Ø14	F-14	1450	80,80	
500	20"	432,5	380	127	593	38	36	210	850,5	-	-	140	4 x Ø18	F-14	1800	113,60	
600	24"	494	440	154	690	80	60	210	1014	-	-	165	4 x Ø22	F-16	3450	170,60	
700	28"	590	490	165	830	106	65	300	1186	-	-	254	8 x Ø18	F-25	5000	252	
800	32"	630	565	190	902	106	80	300	1301	-	-	254	8 x Ø18	F-25	6500	347	
900	36"	695	610	203	1010	110	80	350	1415	-	-	254	8 x Ø18	F-25	8500	457	
1000	40"	770	675	216	1116	110	80	350	1555	-	-	254	8 x Ø18	F-25	11500	580	
1200	48"	875	818	254	1334	110	100	350	1803	-	-	298	8 x Ø23	F-30	15500	959	

Konstruktionsänderungen vorbehalten.

Ausgabe 06/2016



Figur **497**

Zwischenflanschsanschluss
Durchgangsform

ABMESSUNGEN

Hebel 497 DN32 - DN200

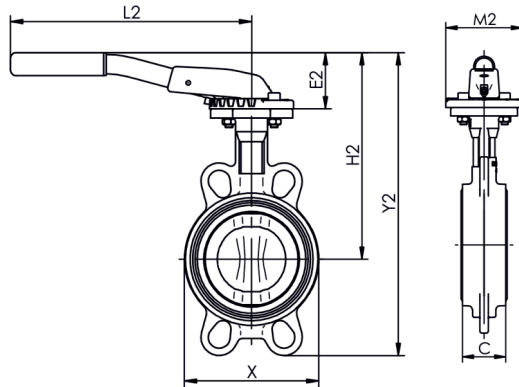

Gearbox 497 DN32 - DN1200

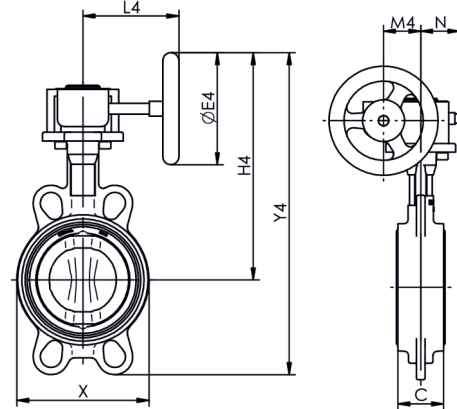

DN		Hebel						Gearbox						
		E2	H2	Y2	L2	M2		E4	H4	Y4	L4	M4	N	
mm	inch	mm					kg	mm					kg	
32	1 1/4"	49	151	212	220	90	1,90	125	190	251	128	43,5	50	2,70
40	1 1/2"	49	159	215	220	90	2,10	125	198	254	128	43,5	50	2,90
50	2"	49	169	230	220	90	2,90	125	208	269	128	43,5	50	3,70
65	2 1/2"	49	184	253	220	90	3,00	125	223	292	128	43,5	50	3,80
80	3"	60	201	295	260	90	3,60	125	229	323	128	43,5	50	4,30
100	4"	60	225	331	260	90	4,40	125	253	359	128	43,5	50	5,20
125	5"	75	255	381	315	90	6,60	160	286	412	135	43,5	50	7,50
150	6"	75	268	401	315	90	7,60	160	298	431	135	43,5	50	8,70
200	8"	75	300	470	315	90	11,60	200	355	525	152	52,5	57	13,60
250	10"	-	-	-	-	-	-	250	442	652	222	61	70	24,00
300	12"	-	-	-	-	-	-	250	468	708	222	61	70	33,00
350	14"	-	-	-	-	-	-	250	498	761	222	61	70	39,00
400	16"	-	-	-	-	-	-	300	572	880	278	69	72,5	64,60
450	18"	-	-	-	-	-	-	400	630	970	321	96,5	91,5	99,20
500	20"	-	-	-	-	-	-	400	682	1062	321	96,5	91,5	132,00
600	24"	-	-	-	-	-	-	500	799	1239	408	137,5	140	205,00
700	28"	-	-	-	-	-	-	600	945	1435	424	137,5	140	325,00
800	32"	-	-	-	-	-	-	600	985	1550	456	137,5	140	404,00
900	36"	-	-	-	-	-	-	700	1108	1718	510	180	156	557,00
1000	40"	-	-	-	-	-	-	700	1183	1858	579	180	156	659,00
1200	48"	-	-	-	-	-	-	700	1310	2128	593	252	201	1128,00

Konstruktionsänderungen vorbehalten.

Ausgabe 06/2016



Figur **497**

Zwischenflanschsanschluss
Durchgangsform

KV KOEFFIZIENT

DN	32/40	50	65	80	100	125	150	200	250	300	350	400	450	500	600	700	800	900	1000	1200	
Opening angle	25°	2,5	5	8,6	13	24	52	146	146	224	327	430	560	775	970	1293	1350	1600	1800	2500	5400
	30°	4,3	7,7	12,9	19	36	76	125	215	336	475	645	775	1077	1380	1895	1990	2200	2300	3800	7800
	40°	9	14	22	33	63	133	215	360	580	860	1120	1465	1980	2415	3275	3860	4500	6100	8700	12500
	50°	15	23	36	54	103	215	353	603	990	1380	1896	2285	3190	3965	5260	5980	8200	10400	13500	22600
	60°	22	45	70	110	200	420	690	1120	1850	2670	3535	4395	6120	7500	10130	10600	12500	17500	23000	35500
	70°	38	60	90	138	260	540	890	1510	3190	3490	4395	5600	7930	9900	14225	17100	20000	29000	37500	61500
	80°	60	90	138	207	410	860	1420	2350	3700	5215	6980	9310	12700	15085	20700	25300	29000	42000	59200	82000
	90°	68	112	172	258	474	970	1680	2800	4310	6465	8620	10775	15086	18965	24137	36000	44000	58000	80500	110500

AUSFÜHRUNG

Figur	Gehäusewerkstoff	Nennweite DN	Nenndruck PN	Ausführung
497	A Grauguss EN-GJL-250	32-150 mm	C 16bar	06-I • Scheibe- Edelstahl, ohne Hebel, EPDM - Dichtung Tmax 110 °C
		200-900 mm	B 10bar	06-I • Scheibe- Edelstahl, ohne Hebel, EPDM - Dichtung Tmax 110 °C
		1000-1200 mm	A 6bar	06-I • Scheibe- Edelstahl, ohne Hebel, EPDM - Dichtung Tmax 110 °C
		32-150 mm	C 16bar	26-I • Scheibe- Sphäroguss, ohne Hebel, EPDM - Dichtung Tmax 110 °C
		200-900 mm	B 10bar	26-I • Scheibe- Sphäroguss, ohne Hebel, EPDM - Dichtung Tmax 110 °C
		1000-1200 mm	A 6bar	26-I • Scheibe- Sphäroguss, ohne Hebel, EPDM - Dichtung Tmax 110 °C
		32-150 mm	C 16bar	36-I • Scheibe- Edelstahl, Hebel, EPDM - Dichtung Tmax 110 °C
		200-300 mm	B 10bar	36-I • Scheibe- Edelstahl, Hebel, EPDM - Dichtung Tmax 110 °C
		32-150 mm	C 16bar	66-I • Scheibe- Sphäroguss, Hebel, EPDM - Dichtung Tmax 110 °C
		200-300 mm	B 10bar	66-I • Scheibe- Sphäroguss, Hebel, EPDM - Dichtung Tmax 110 °C

Konstruktionsänderungen vorbehalten.

Ausgabe 06/2016

**Figur 497**Zwischenflanschsanschluss
Durchgangsform**AUSFÜHRUNG**

Figur	Gehäusewerkstoff	Nennweite DN	Nenndruck PN	Ausführung
497	A Grauguss EN-GJL-250	32-150 mm	C 16bar	66-I • Scheibe- Sphäroguss, Hebel, EPDM - Dichtung Tmax 110 °C
		200-300 mm	B 10bar	66-I • Scheibe- Sphäroguss, Hebel, EPDM - Dichtung Tmax 110 °C
		32-150 mm	C 16bar	A6-I • Scheibe- Edelstahl, Gearbox, EPDM - Dichtung Tmax 110 °C
		200-900 mm	B 10bar	A6-I • Scheibe- Edelstahl, Gearbox, EPDM - Dichtung Tmax 110 °C
		1000-1200 mm	A 6bar	A6-I • Scheibe- Edelstahl, Gearbox, EPDM - Dichtung Tmax 110 °C
		32-150 mm	C 16bar	C6-I • Scheibe- Sphäroguss, Gearbox, EPDM - Dichtung Tmax 110 °C
		200-900 mm	B 10bar	C6-I • Scheibe- Sphäroguss, Gearbox, EPDM - Dichtung Tmax 110 °C
		1000-1200 mm	A 6bar	C6-I • Scheibe- Sphäroguss, Gearbox, EPDM - Dichtung Tmax 110 °C
		B Sphäroguss EN-GJS-400-15	32-150 mm	C 16bar
	200-1200 mm		B 10bar	06-I • Scheibe- Edelstahl, ohne Hebel, EPDM - Dichtung Tmax 110 °C
	32-150 mm		C 16bar	26-I • Scheibe- Sphäroguss, ohne Hebel, EPDM - Dichtung Tmax 110 °C
	200-1200 mm		B 10bar	26-I • Scheibe- Sphäroguss, ohne Hebel, EPDM - Dichtung Tmax 110 °C
	32-150 mm		C 16bar	36-I • Scheibe- Edelstahl, Hebel, EPDM - Dichtung Tmax 110 °C
	200-300 mm		B 10bar	36-I • Scheibe- Edelstahl, Hebel, EPDM - Dichtung Tmax 110 °C



AUSFÜHRUNG

Figur	Gehäusewerkstoff	Nennweite DN	Nenndruck PN	Ausführung
497	B Sphäroguss EN-GJS-400-15	32-150 mm	C 16bar	66-I • Scheibe- Sphäroguss, Hebel, EPDM - Dichtung Tmax 110 °C
		200-300 mm	B 10bar	66-I • Scheibe- Sphäroguss, Hebel, EPDM - Dichtung Tmax 110 °C
		32-150 mm	C 16bar	A6-I • Scheibe- Edelstahl, Gearbox, EPDM - Dichtung Tmax 110 °C
		200-1200 mm	B 10bar	A6-I • Scheibe- Edelstahl, Gearbox, EPDM - Dichtung Tmax 110 °C
		32-150 mm	C 16bar	C6-I • Scheibe- Sphäroguss, Gearbox, EPDM - Dichtung Tmax 110 °C
		200-1200 mm	B 10bar	C6-I • Scheibe- Sphäroguss, Gearbox, EPDM - Dichtung Tmax 110 °C

BESTELLANGABEN

Das Produkt mit Indexangabe bestellen



BESTELLBEISPIEL

